

WESTERBEKE 3 KW MARINE DIESEL GENERATOR SET

**Dependable Electricity
for small boats
at 1800 quiet RPM**

A small, reliable, smooth running Generator Set for all your shipboard needs; 120 volt electrical power at the turn of a switch for: Electric Cooking, Microwave Oven, Refrigeration, Cabin Appliances, Power Tools, and Navigation/Communication Equipment. Like all Westerbeke Generator Sets, it is fresh water cooled with an Engine mounted Heat Exchanger. The Engine and Generator are connected through special "Commonized" Drive Discs, Flywheel, and Flywheel Housing into a compact, carefully aligned Generator Set. The complete unit is mounted on lightweight rails through soft flexible Isolator Mounts that prevent the transfer of vibration. A lightweight removable Drip Tray is fitted under the unit between the mounting rails. The Engine is fitted with an Electric Fuel Pump and Self-Bleeding Fuel System that eliminates hand priming and bleeding. Cast iron cylinder head and block plus swirl type combustion chamber produce quiet running unmatched in the industry.

**FOR POWER OR SAILBOAT ... A NEW SERIES OF
DIESEL GENERATOR SETS FROM WESTERBEKE.**

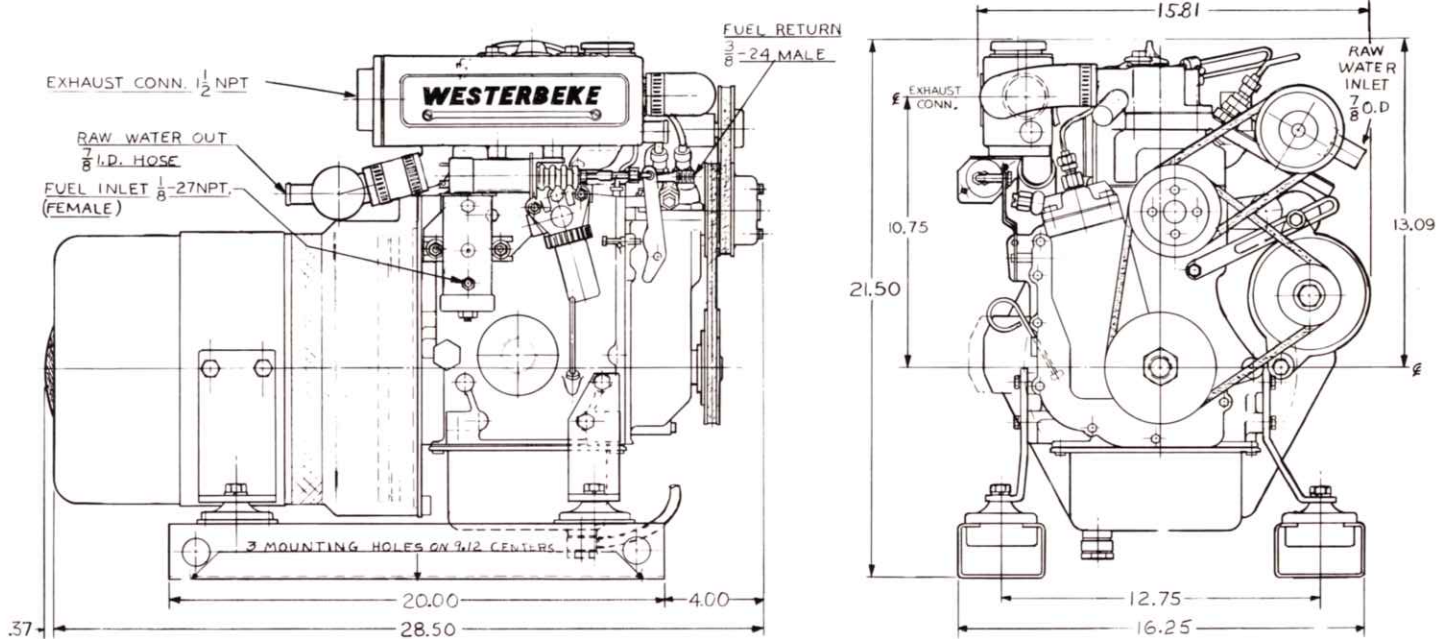

DESIGN: Four pole revolving armature, inherently regulated, self limiting, rectifier excited, A.C. slip rings, single bearing design.

VOLTAGE REGULATION: ±7% no load to full load.

FREQUENCY REGULATION: 3 Hertz (5%) no load to full load.

INSULATION: Class F as defined by NEMA MGI-1.65

TEMPERATURE RISE: Within NEMA MGI-22.40 definition when operating @ full load.

COOLING: Centrifugal blower, direct connected.

RADIO INTERFERENCE LEVEL: Capacitors minimize interference within the limits of most marine applications.

ARMATURE: Balanced laminated steel, double dipped and baked.

| ELECTRICAL CHARACTERISTICS | | | | | | RATINGS | | DERATINGS | | ENGINE | |
|----------------------------|---------|---------|-------|-------|------|--------------|-----|--|--|--------|--------|
| Model | Volts | Amps | Hertz | Phase | Wire | Power Factor | KW | | | RPM | Start |
| 3.0-612 | 120 | 25 | 60 | 1 | 2 | 1.0 | 3.0 | 3.5% each 1000 feet above sea level. | | 1800 | Remote |
| 3.0-613 | 120/240 | 25/12.5 | 60 | 1 | 3 | 1.0 | 3.0 | 1% for each 10° Fahrenheit above 85° Fahrenheit ambient. | | 1800 | Remote |
| 2.4-512 | 120 | 21 | 50 | 1 | 2 | 1.0 | 2.4 | | | 1500 | Remote |
| 2.4-513 | 120/240 | 21/10.5 | 50 | 1 | 3 | 1.0 | 2.4 | | | 1500 | Remote |



GENERATORS: 3, 4.4, 7.7, 11, 12.5, 15, 20, 25, 32, 45

Fresh Water Cooled Diesel Generators from Westerbeke.

DESIGN FEATURES

Special attention was paid throughout the design to noise levels. A Bosch type fuel injection pump is used which limits fuel quantity in the first part of the injection stroke. This, together with a throttle-type injection nozzle and a swirl combustion chamber, prevents an abrupt rise in cylinder pressure and softens combustion noise.

To avoid resonance of the cylinder block, the crankcase is carefully ribbed for rigidity.

Despite the engine's small dimensions, there still is a stroke of 2.68 inches. Three compression rings and one oil control ring are used for good balance of the moving piston and further reduction of mechanical noise and vibration.

The valve cover is cast — not stamped — a noise damping component.

Both cylinder block and head are cast iron which is more sound deadening, rigid, and long-lived than aluminum.

The result is sound expressed in DB(a) readings at one meter with full load, of 86 Decibels at 1800 RPM. Using optional Sound Guard Decibels reduce to 69 — truly remarkable performance.

Additionally, less blow-by, better thermal flow, less friction loss, and lower oil consumption, leading to longer life between overhauls, are the result of these studies.

Engine starting has been given special attention. An automatic fuel advance system, along with the starting motor, makes starting easy at 50°F. For lower temperatures, preheating glow plugs are standard equipment.

The engine is designed with easier maintenance in mind. For example, the camshaft and governor shaft are gear driven in the normal fashion, but the fuel injection pump and oil pump are built in and driven by the main camshaft. Simplicity of design has produced a thoroughly modern engine of less than 350 parts, so arranged that injection pump, governor, throttle lever, fuel filter, cartridge type oil filter, and oil dipstick are all on the same side of the engine.

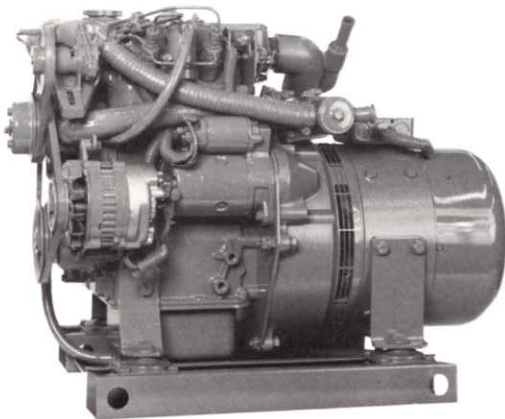

ENGINE SPECIFICATIONS

| | |
|--------------------|-----------------------------|
| Engine Type | 2 cyl., 4 cycle, OHV Diesel |
| Bore & Stroke | 2.56 in. x 2.68 in. |
| Displacement | 27.52 cu. inches |
| Compression Ratio | 25:1 |
| Lubrication | Pressure by Trochoid Pump |
| Injection Pump | Bosch Type |
| Nozzles | Throttle Type |
| Governor | Centrifugal Weight Type |
| Starter | Solenoid Shift Type |
| Alternator | 35 Ampere |
| Glow Plugs | Quick Heat Type |
| Fuel Transfer Pump | Electric Plunger Type |
| Fuel Consumption | Approx. 0.4 GPH |
| Total Weight | 308 Pounds |

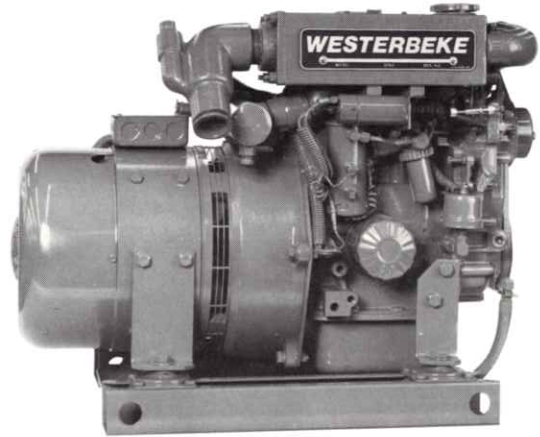

STANDARD EQUIPMENT

Remote Instrument Panel • 15' cable for remote panel
 12 volt 35 ampere alternator • Coolant recovery tank
 Fresh water cooling system • Operators manual • 12 volt starting motor • Vibration Isolators • Water Injected Exhaust elbow • Drip Tray • High water temperature and low oil pressure shutdown • High exhaust temperature shutdown • Emergency stop switch

OPTIONAL EQUIPMENT

"Sound/Guard" sound enclosure • Hydro hush silencer
 Protective full sedimenter/water trap filter • Ship to shore transfer switch • Remote start/stop panel



PANEL WITH HOUR METER



START/STOP PANEL



TRANSFER SWITCH

CALL YOUR WESTERBEKE REPRESENTATIVE

OR CONTACT THE . . .



J. H. WESTERBEKE CORP.

WESTERBEKE 3 KW MARINE DIESEL GENERATOR SET

**Dependable Electricity
for small boats
at 1800 quiet RPM**

A small, reliable, smooth running Generator Set for all your shipboard needs; 120 volt electrical power at the turn of a switch for: Electric Cooking, Microwave Oven, Refrigeration, Cabin Appliances, Power Tools, and Navigation/Communication Equipment. Like all Westerbeke Generator Sets, it is fresh water cooled with an Engine mounted Heat Exchanger. The Engine and Generator are connected through special "Commonized" Drive Discs, Flywheel, and Flywheel Housing into a compact, carefully aligned Generator Set. The complete unit is mounted on lightweight rails through soft flexible Isolator Mounts that prevent the transfer of vibration. A lightweight removable Drip Tray is fitted under the unit between the mounting rails. The Engine is fitted with an Electric Fuel Pump and Self-Bleeding Fuel System that eliminates hand priming and bleeding. Cast iron cylinder head and block plus swirl type combustion chamber produce quiet running unmatched in the industry.

**FOR POWER OR SAILBOAT ... A NEW SERIES OF
DIESEL GENERATOR SETS FROM WESTERBEKE.**

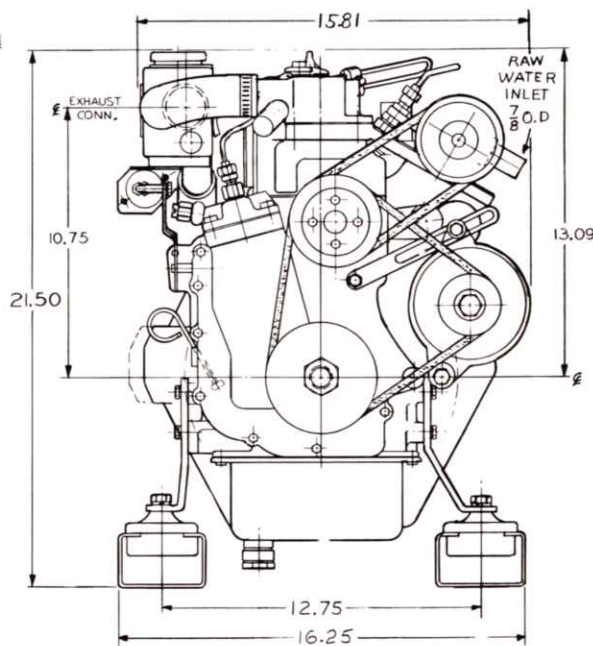
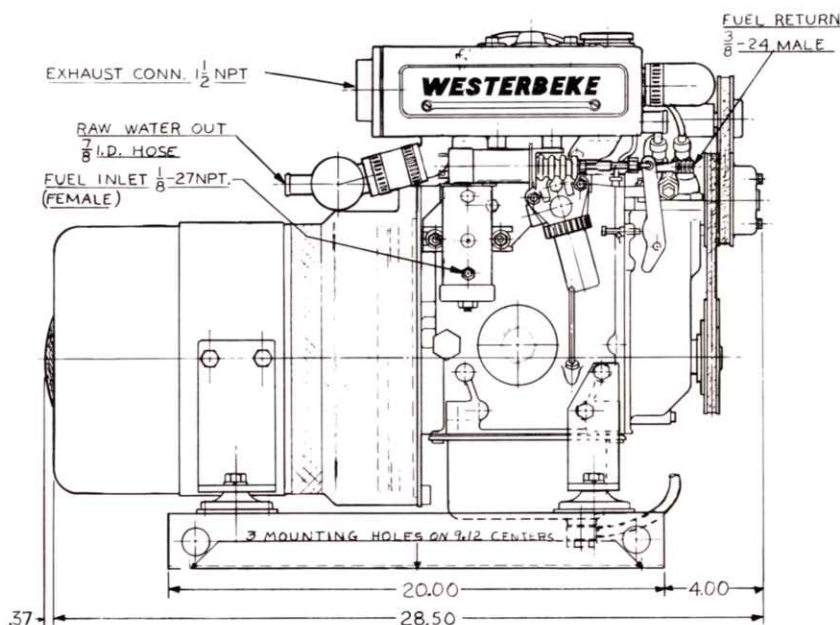

DESIGN: Four pole revolving armature, inherently regulated, self limiting, rectifier excited, A.C. slip rings, single bearing design.
VOLTAGE REGULATION: ±7% no load to full load.
FREQUENCY REGULATION: 3 Hertz (5%) no load to full load.
INSULATION: Class F as defined by NEMA MGI-1.65

TEMPERATURE RISE: Within NEMA MGI-22.40 definition when operating @ full load.
COOLING: Centrifugal blower, direct connected.
RADIO INTERFERENCE LEVEL: Capacitors minimize interference within the limits of most marine applications.
ARMATURE: Balanced laminated steel, double dipped and baked.

| ELECTRICAL CHARACTERISTICS | | | | | | RATINGS | | DERATINGS | | ENGINE | |
|----------------------------|---------|---------|-------|-------|------|--------------|-----|--------------------------------------|--|--------|--------|
| Model | Volts | Amps | Hertz | Phase | Wire | Power Factor | KW | | | RPM | Start |
| 3.0-612 | 120 | 25 | 60 | 1 | 2 | 1.0 | 3.0 | 3.5% each 1000 feet above sea level. | 1% for each 10° Fahrenheit above 85° Fahrenheit ambient. | 1800 | Remote |
| 3.0-613 | 120/240 | 25/12.5 | 60 | 1 | 3 | 1.0 | 3.0 | | | 1800 | Remote |
| 2.4-512 | 120 | 21 | 50 | 1 | 2 | 1.0 | 2.4 | | | 1500 | Remote |
| 2.4-513 | 120/240 | 21/10.5 | 50 | 1 | 3 | 1.0 | 2.4 | | | 1500 | Remote |



GENERATORS: 3, 4.4, 7.7, 11, 12.5, 15, 20, 25, 32, 45

Fresh Water Cooled Diesel Generators from Westerbeke.

DESIGN FEATURES

Special attention was paid throughout the design to noise levels. A Bosch type fuel injection pump is used which limits fuel quantity in the first part of the injection stroke. This, together with a throttle-type injection nozzle and a swirl combustion chamber, prevents an abrupt rise in cylinder pressure and softens combustion noise.

To avoid resonance of the cylinder block, the crankcase is carefully ribbed for rigidity.

Despite the engine's small dimensions, there still is a stroke of 2.68 inches. Three compression rings and one oil control ring are used for good balance of the moving piston and further reduction of mechanical noise and vibration.

The valve cover is cast — not stamped — a noise damping component.

Both cylinder block and head are cast iron which is more sound deadening, rigid, and long-lived than aluminum.

The result is sound expressed in DB(a) readings at one meter with full load, of 86 Decibels at 1800 RPM. Using optional Sound Guard Decibels reduce to 69 — truly remarkable performance.

Additionally, less blow-by, better thermal flow, less friction loss, and lower oil consumption, leading to longer life between overhauls, are the result of these studies.

Engine starting has been given special attention. An automatic fuel advance system, along with the starting motor, makes starting easy at 50°F. For lower temperatures, preheating glow plugs are standard equipment.

The engine is designed with easier maintenance in mind. For example, the camshaft and governor shaft are gear driven in the normal fashion, but the fuel injection pump and oil pump are built in and driven by the main camshaft. Simplicity of design has produced a thoroughly modern engine of less than 350 parts, so arranged that injection pump, governor, throttle lever, fuel filter, cartridge type oil filter, and oil dipstick are all on the same side of the engine.

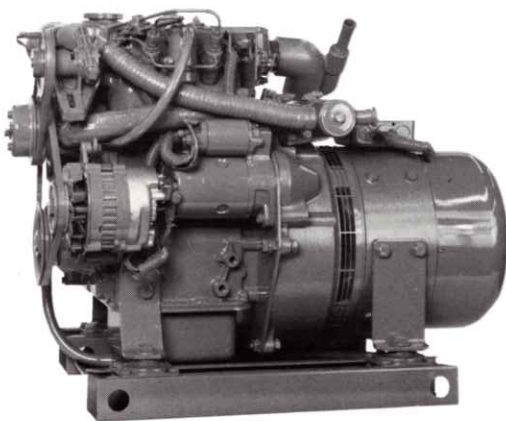

ENGINE SPECIFICATIONS

| | |
|--------------------|-----------------------------|
| Engine Type | 2 cyl., 4 cycle, OHV Diesel |
| Bore & Stroke | 2.56 in. x 2.68 in. |
| Displacement | 27.52 cu. inches |
| Compression Ratio | 25:1 |
| Lubrication | Pressure by Trochoid Pump |
| Injection Pump | Bosch Type |
| Nozzles | Throttle Type |
| Governor | Centrifugal Weight Type |
| Starter | Solenoid Shift Type |
| Alternator | 35 Ampere |
| Glow Plugs | Quick Heat Type |
| Fuel Transfer Pump | Electric Plunger Type |
| Fuel Consumption | Approx. 0.4 GPH |
| Total Weight | 308 Pounds |

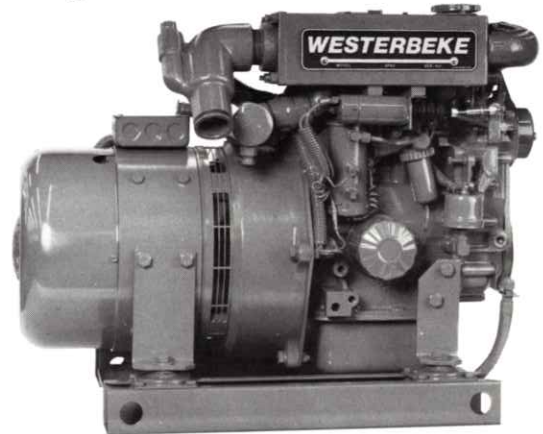

STANDARD EQUIPMENT

Remote Instrument Panel • 15' cable for remote panel
 12 volt 35 ampere alternator • Coolant recovery tank
 Fresh water cooling system • Operators manual • 12 volt starting motor • Vibration Isolators • Water Injected Exhaust elbow • Drip Tray • High water temperature and low oil pressure shutdown • High exhaust temperature shutdown • Emergency stop switch

OPTIONAL EQUIPMENT

"Sound/Guard" sound enclosure • Hydro hush silencer
 Protective full sedimenter/water trap filter • Ship to shore transfer switch • Remote start/stop panel



PANEL WITH HOUR METER



START/STOP PANEL



TRANSFER SWITCH

CALL YOUR WESTERBEKE REPRESENTATIVE

OR CONTACT THE . . .



J. H. WESTERBEKE CORP.

WESTERBEKE 3 KW MARINE DIESEL GENERATOR SET

Dependable Electricity
for small boats
at 1800 quiet RPM

A small, reliable, smooth running Generator Set for all your shipboard needs; 120 volt electrical power at the turn of a switch for: Electric Cooking, Microwave Oven, Refrigeration, Cabin Appliances, Power Tools, and Navigation/Communication Equipment. Like all Westerbeke Generator Sets, it is fresh water cooled with an Engine mounted Heat Exchanger. The Engine and Generator are connected through special "Commonized" Drive Discs, Flywheel, and Flywheel Housing into a compact, carefully aligned Generator Set. The complete unit is mounted on lightweight rails through soft flexible Isolator Mounts that prevent the transfer of vibration. A lightweight removable Drip Tray is fitted under the unit between the mounting rails. The Engine is fitted with an Electric Fuel Pump and Self-Bleeding Fuel System that eliminates hand priming and bleeding. Cast iron cylinder head and block plus swirl type combustion chamber produce quiet running unmatched in the industry.

FOR POWER OR SAILBOAT ... A NEW SERIES OF
DIESEL GENERATOR SETS FROM WESTERBEKE.

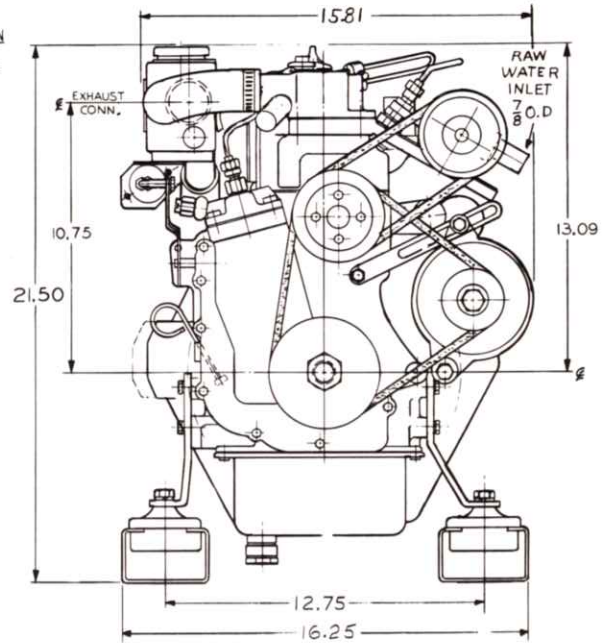
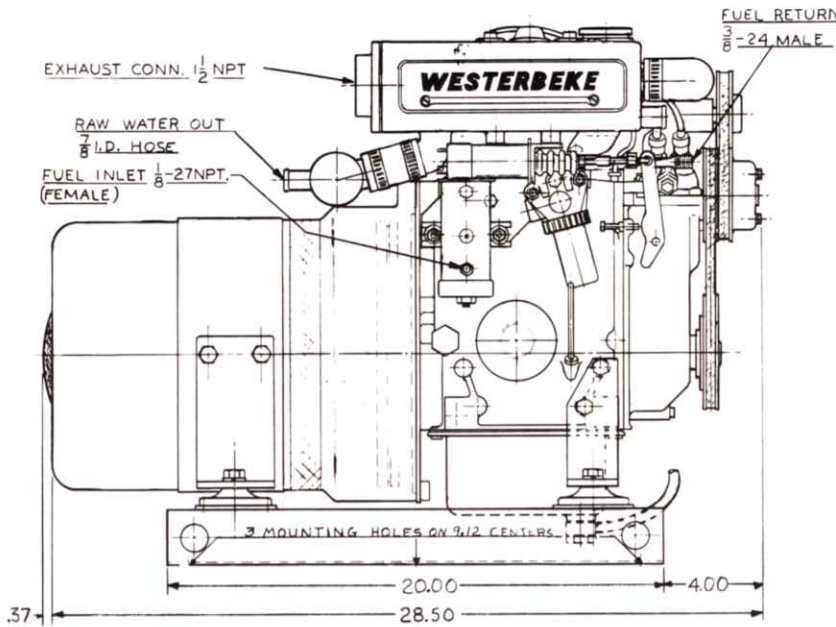

DESIGN: Four pole revolving armature, inherently regulated, self limiting, rectifier excited, A.C. slip rings, single bearing design.

VOLTAGE REGULATION: ±7% no load to full load.

FREQUENCY REGULATION: 3 Hertz (5%) no load to full load.

INSULATION: Class F as defined by NEMA MGI-1.65

TEMPERATURE RISE: Within NEMA MGI-22.40 definition when operating @ full load.

COOLING: Centrifugal blower, direct connected.

RADIO INTERFERENCE LEVEL: Capacitors minimize interference within the limits of most marine applications.

ARMATURE: Balanced laminated steel, double dipped and baked.

| ELECTRICAL CHARACTERISTICS | | | | | | RATINGS | | DERATINGS | ENGINE | |
|----------------------------|---------|---------|-------|-------|------|--------------|-----|--|--------|--------|
| Model | Volts | Amps | Hertz | Phase | Wire | Power Factor | KW | | RPM | Start |
| 3.0-612 | 120 | 25 | 60 | 1 | 2 | 1.0 | 3.0 | 3.5% each 1000 feet above sea level. | 1800 | Remote |
| 3.0-613 | 120/240 | 25/12.5 | 60 | 1 | 3 | 1.0 | 3.0 | | 1800 | Remote |
| 2.4-512 | 120 | 21 | 50 | 1 | 2 | 1.0 | 2.4 | 1% for each 10° Fahrenheit above 85° Fahrenheit ambient. | 1500 | Remote |
| 2.4-513 | 120/240 | 21/10.5 | 50 | 1 | 3 | 1.0 | 2.4 | | 1500 | Remote |



GENERATORS: 3, 4.4, 7.7, 11, 12.5, 15, 20, 25, 32, 45

Fresh Water Cooled Diesel Generators from Westerbeke.

DESIGN FEATURES

Special attention was paid throughout the design to noise levels. A Bosch type fuel injection pump is used which limits fuel quantity in the first part of the injection stroke. This, together with a throttle-type injection nozzle and a swirl combustion chamber, prevents an abrupt rise in cylinder pressure and softens combustion noise.

To avoid resonance of the cylinder block, the crankcase is carefully ribbed for rigidity.

Despite the engine's small dimensions, there still is a stroke of 2.68 inches. Three compression rings and one oil control ring are used for good balance of the moving piston and further reduction of mechanical noise and vibration.

The valve cover is cast — not stamped — a noise damping component.

Both cylinder block and head are cast iron which is more sound deadening, rigid, and long-lived than aluminum.

The result is sound expressed in DB(a) readings at one meter with full load, of 86 Decibels at 1800 RPM. Using optional Sound Guard Decibels reduce to 69 — truly remarkable performance.

Additionally, less blow-by, better thermal flow, less friction loss, and lower oil consumption, leading to longer life between overhauls, are the result of these studies.

Engine starting has been given special attention. An automatic fuel advance system, along with the starting motor, makes starting easy at 50°F. For lower temperatures, preheating glow plugs are standard equipment.

The engine is designed with easier maintenance in mind. For example, the camshaft and governor shaft are gear driven in the normal fashion, but the fuel injection pump and oil pump are built in and driven by the main camshaft. Simplicity of design has produced a thoroughly modern engine of less than 350 parts, so arranged that injection pump, governor, throttle lever, fuel filter, cartridge type oil filter, and oil dipstick are all on the same side of the engine.

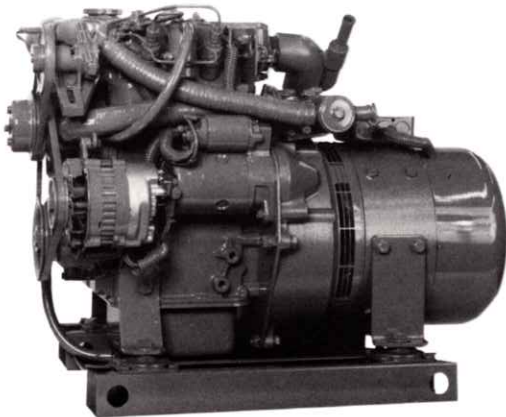

ENGINE SPECIFICATIONS

| | |
|--------------------|-----------------------------|
| Engine Type | 2 cyl., 4 cycle, OHV Diesel |
| Bore & Stroke | 2.56 in. x 2.68 in. |
| Displacement | 27.52 cu. inches |
| Compression Ratio | 25:1 |
| Lubrication | Pressure by Trochoid Pump |
| Injection Pump | Bosch Type |
| Nozzles | Throttle Type |
| Governor | Centrifugal Weight Type |
| Starter | Solenoid Shift Type |
| Alternator | 35 Ampere |
| Glow Plugs | Quick Heat Type |
| Fuel Transfer Pump | Electric Plunger Type |
| Fuel Consumption | Approx. 0.4 GPH |
| Total Weight | 308 Pounds |

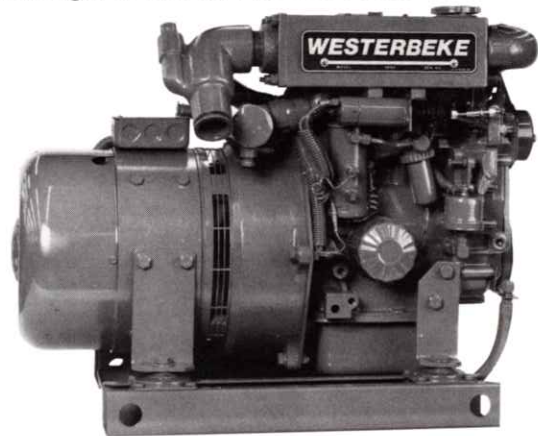

STANDARD EQUIPMENT

Remote Instrument Panel • 15' cable for remote panel
12 volt 35 ampere alternator • Coolant recovery tank
Fresh water cooling system • Operators manual • 12 volt starting motor • Vibration Isolators • Water Injected Exhaust elbow • Drip Tray • High water temperature and low oil pressure shutdown • High exhaust temperature shutdown • Emergency stop switch

OPTIONAL EQUIPMENT

"Sound/Guard" sound enclosure • Hydro hush silencer
Protective full sedimenter/water trap filter • Ship to shore transfer switch • Remote start/stop panel



PANEL WITH
HOUR METER



START/STOP
PANEL



TRANSFER
SWITCH

CALL YOUR WESTERBEKE REPRESENTATIVE

OR CONTACT THE . . .



J. H. WESTERBEKE CORP.

Avon Industrial Park, Avon, MA 02322, (617) 588-7700
Cable: Westcorp, Avon, Telex: 92-4444

| | | |
|----------|------------------|----------|
| DATE | BY | REVISION |
| 10/11/78 | J. H. WESTERBEKE | 1 |
| 11/15/78 | J. H. WESTERBEKE | 2 |
| 12/15/78 | J. H. WESTERBEKE | 3 |
| 01/15/79 | J. H. WESTERBEKE | 4 |
| 02/15/79 | J. H. WESTERBEKE | 5 |
| 03/15/79 | J. H. WESTERBEKE | 6 |
| 04/15/79 | J. H. WESTERBEKE | 7 |
| 05/15/79 | J. H. WESTERBEKE | 8 |
| 06/15/79 | J. H. WESTERBEKE | 9 |
| 07/15/79 | J. H. WESTERBEKE | 10 |
| 08/15/79 | J. H. WESTERBEKE | 11 |
| 09/15/79 | J. H. WESTERBEKE | 12 |

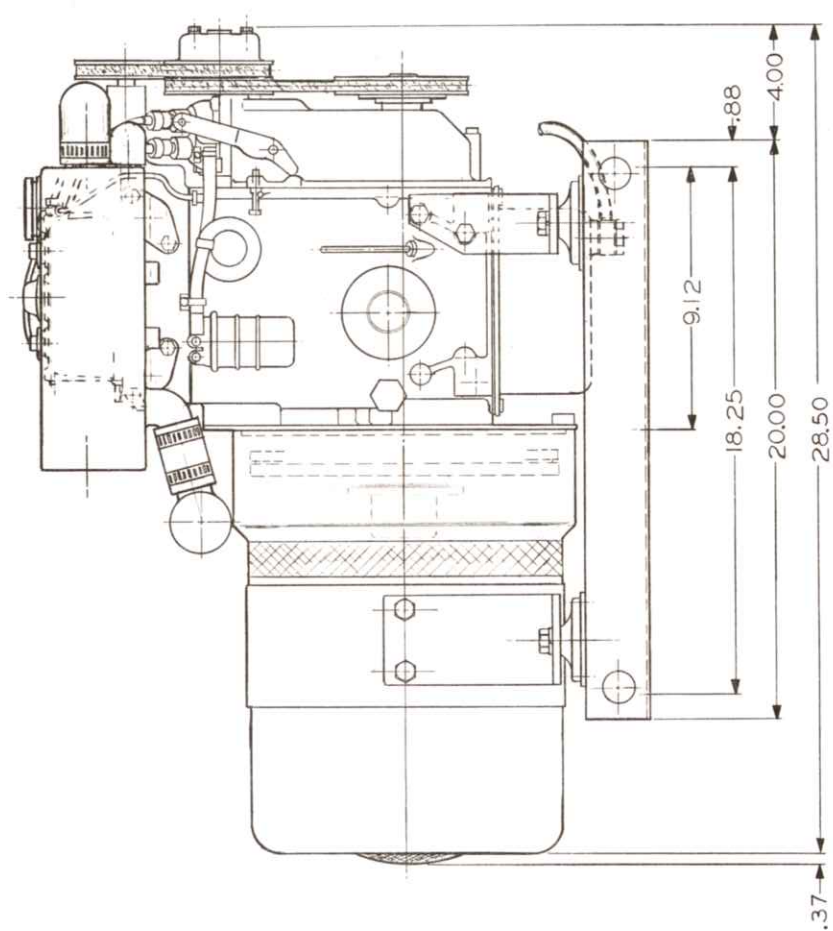
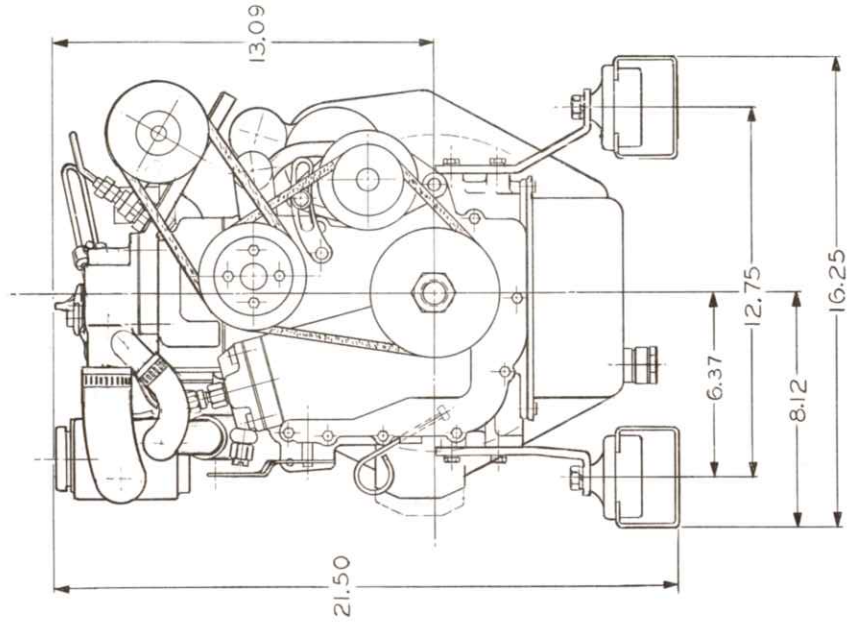

PRELIMINARY

EST'D WEIGHT - 310 LBS

| | |
|-------------|---|
| DESIGNER | J. H. WESTERBEKE |
| CHECKED | J. H. WESTERBEKE |
| DATE | 10/11/78 |
| PROJECT | 3 KW DIESEL GENERATOR, TWO CYLINDER, FRESH WATER COOLED |
| DRAWING NO. | 32271 |
| REV. | 15 MAY 78 |

